

| LOC |     | DIST        |         | REVISIONS |      |  |  |
|-----|-----|-------------|---------|-----------|------|--|--|
| P   | LTR | DESCRIPTION | DATE    | DN        | APVD |  |  |
| A   |     | RELEASED    | 6-11-15 | CT        | DH   |  |  |

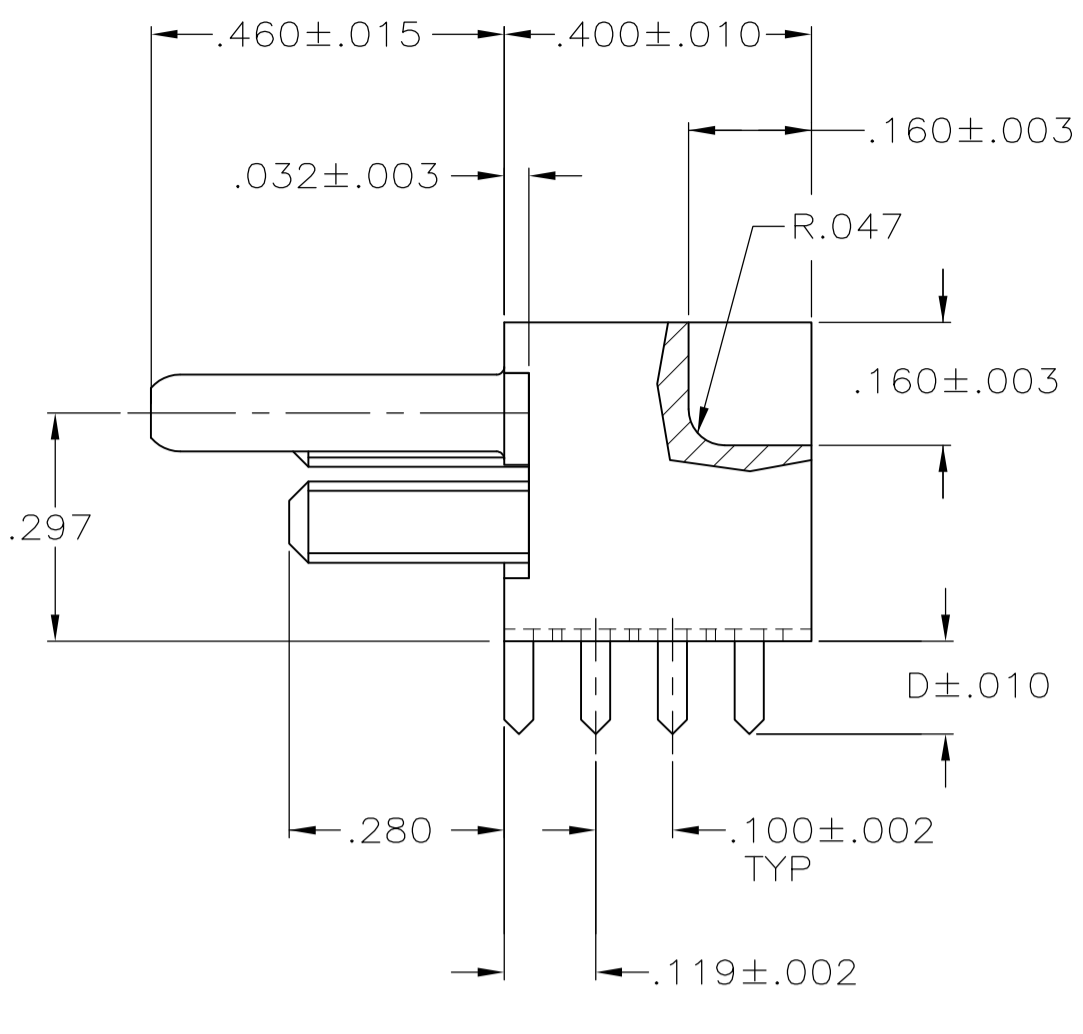

- 1 HOUSING MATERIAL: DAP, COLOR: GREEN (REF COSMIC D72).
- 2 AMP, TE PART NUMBER, & DATE CODE MARKED ON THIS SIDE
- 3 CONTACT MATERIAL: GILDING SPRING METAL.
- 4 CONTACT FINISH: .000050 MIN GOLD IN CONTACT AREA OVER .000050 MIN NICKEL PLATE

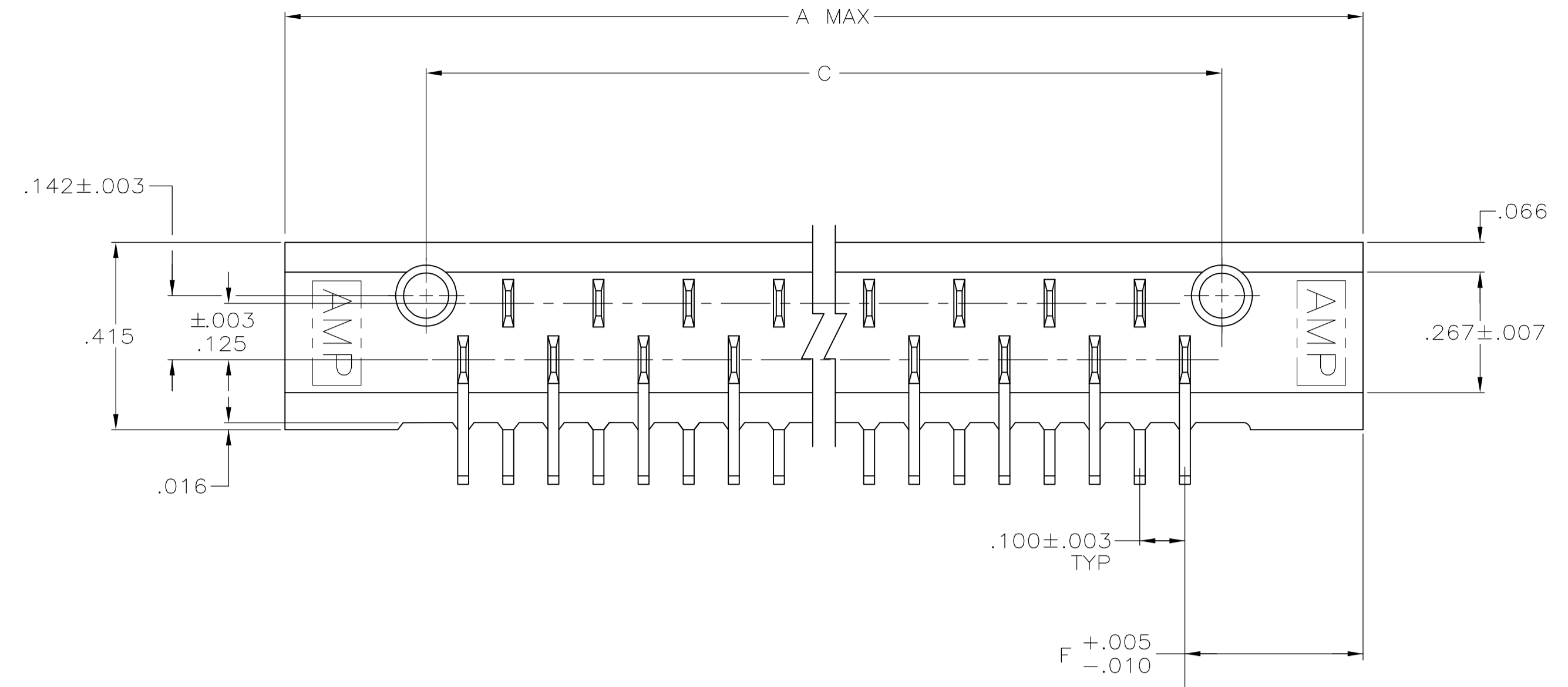
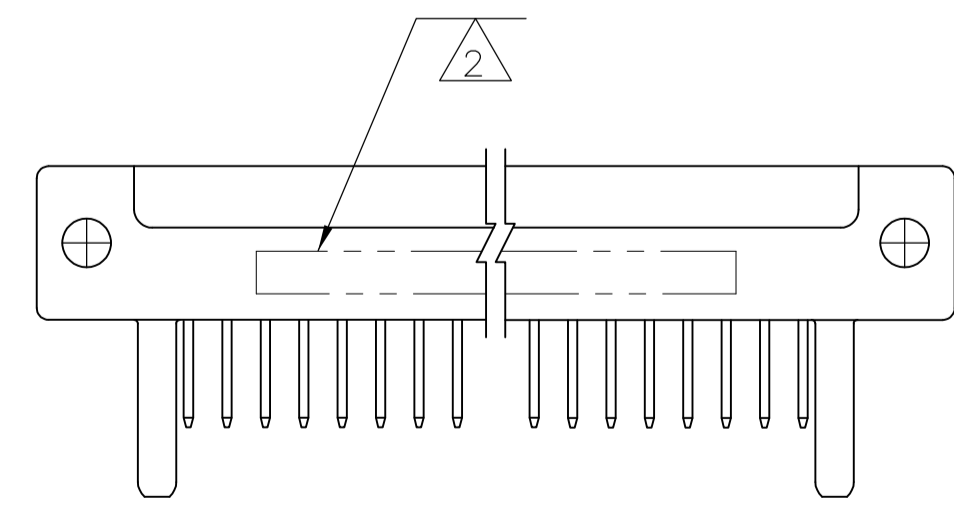
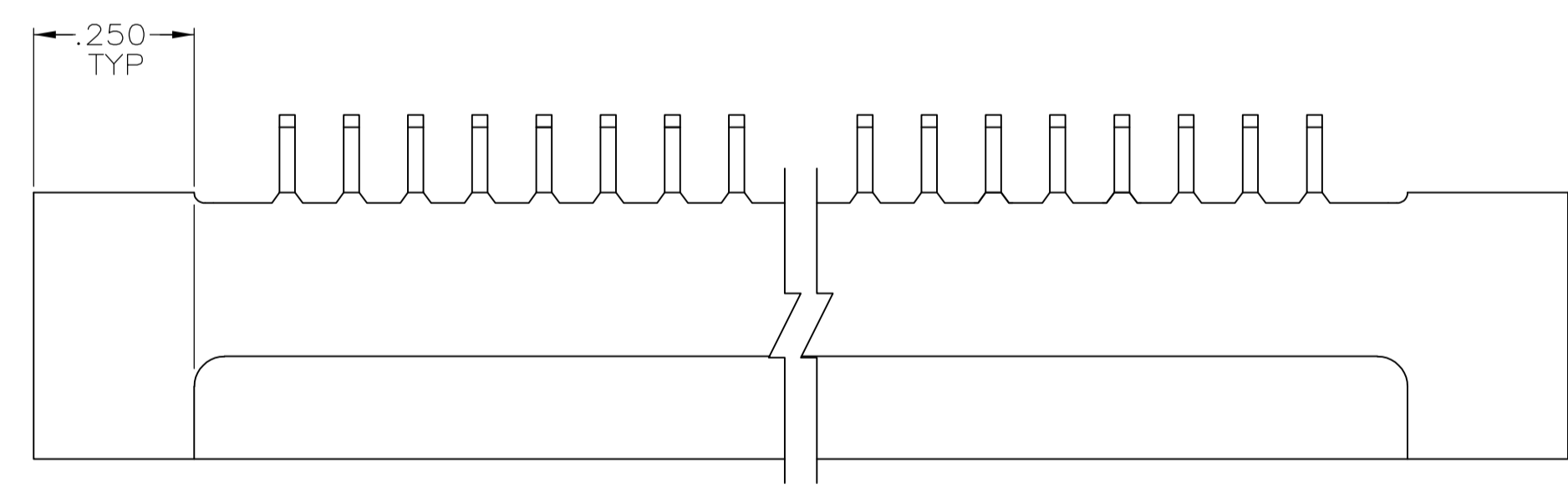
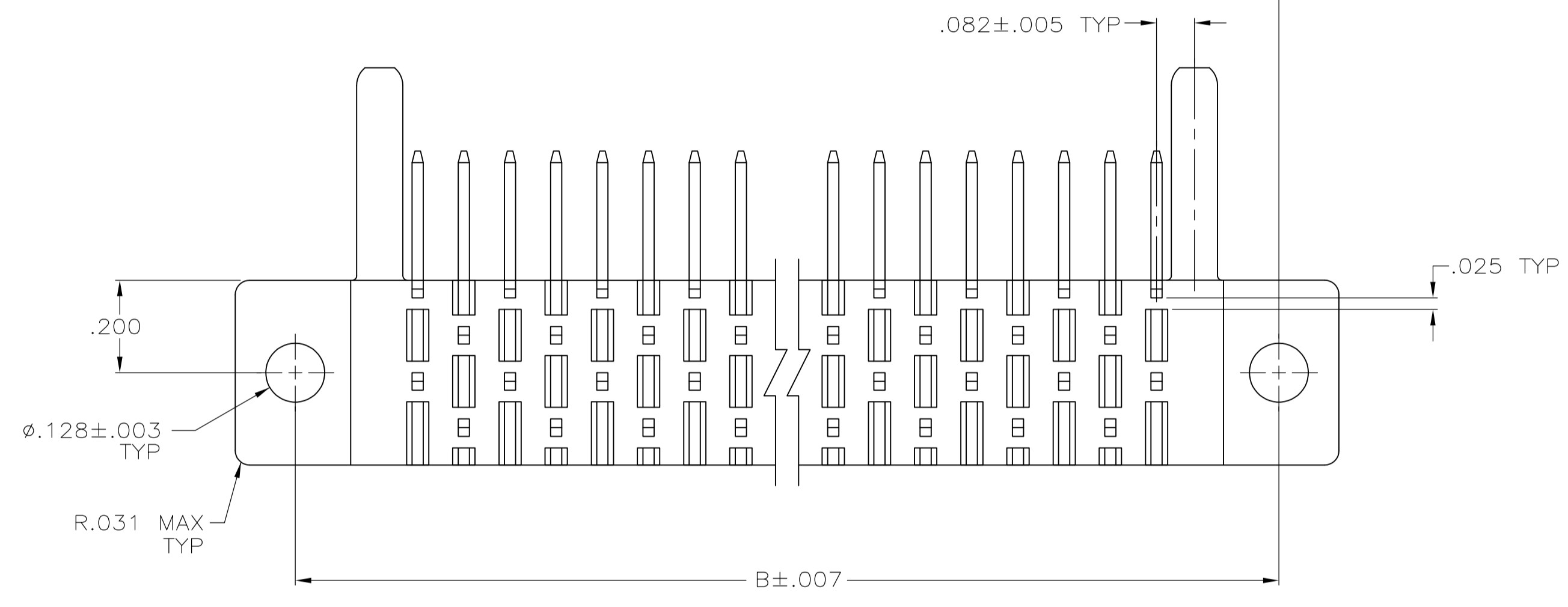

MARKING DETAIL  
NOT TO SCALE

|      |      |      |       |       |       |            |                               |
|------|------|------|-------|-------|-------|------------|-------------------------------|
| .507 | .381 | .120 | 4.764 | 5.363 | 5.623 | 47         | 3- 582308 -1                  |
| F    | E    | D    | C     | B     | A     | NO OF CONT | FINISHED ASSEMBLY PART NUMBER |

|  |  |  |  |   |  |
|--|--|--|--|---|--|
| THIS DRAWING IS A CONTROLLED DOCUMENT. |  | DIN C.C.THOMAS 6-11-15                 |  | TE Connectivity                               |  |
| DIMENSIONS: INCHES                     |  | TOLERANCES UNLESS OTHERWISE SPECIFIED: |  | NAME  |  |
| 0 PLC ± -                              |  | 1 PLC ± -                              |  | ASSEMBLY, AMP BLADE TAB HOUSING               |  |
| 1 PLC ± -                              |  | 2 PLC ± .02                            |  | APPLICATION SPEC                              |  |
| 2 PLC ± .02                            |  | 3 PLC ± .005                           |  | SIZE CAGE CODE DRAWING NO                     |  |
| 3 PLC ± .005                           |  | 4 PLC ± -                              |  | RESTRICTED TO                                 |  |
| 4 PLC ± -                              |  | ANGLES ± °'30"                         |  | WEIGHT  |  |
| MATERIAL                               |  | FINISH                                 |  | A1 00779 C=582308                             |  |
| 1                                      |  | -                                      |  | CUSTOMER DRAWING SCALE 4:1 SHEET 1 OF 1 REV A |  |